

# Analyzing Jitter Using a Spectrum Approach

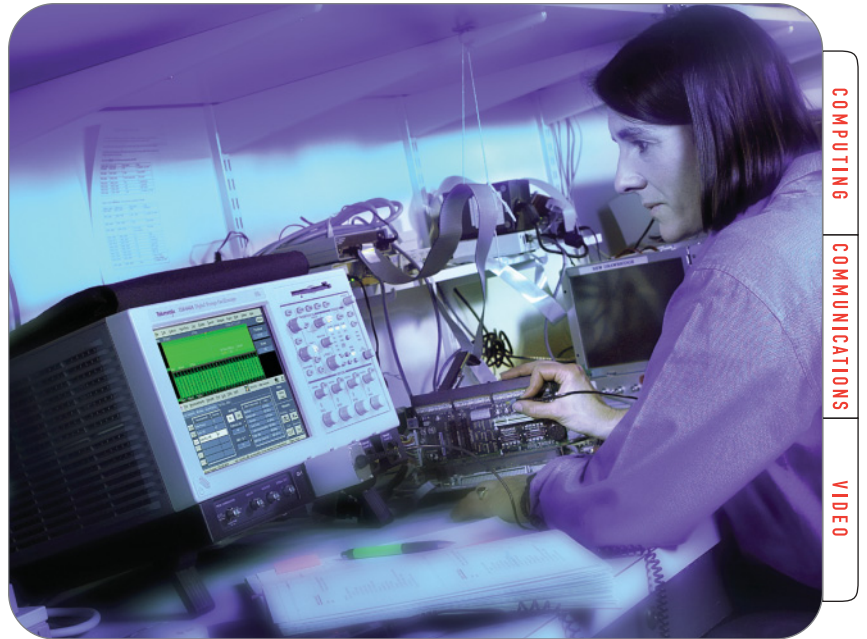

## ▶ Featuring TDSJIT3 Jitter Analysis Software

Use real time jitter analysis tools with Rj/Dj separation to predict system bit error ratio.

### Introduction

As tighter timing margins and faster clock rates drive today's high-speed designs, jitter is becoming a more significant cause of system errors. Jitter component identification and measurement helps to debug high-speed circuits and is required by several high-speed serial data communication standards, such as Fibre Channel, SONET, SDH, and Gigabit Ethernet. This note describes a new way to analyze and measure jitter components using a spectrum analysis approach. Bit error rate (BER) estimation based on the jitter analysis result, takes only seconds as opposed to minutes or even

hours for conventional BER analysis equipment. This method has been implemented with the Tektronix Jitter and Timing Analysis software, TDSJIT3. The software is compatible with TDS6000 and TDS7000 oscilloscopes. This note describes use of TDSJIT3 with a TDS6604 DSO.

This document includes an explanation of:

- ▶ Jitter and its components
- ▶ Jitter component separation using a spectrum approach
- ▶ Bit error ratio estimation

## Jitter Analysis

► Application Note

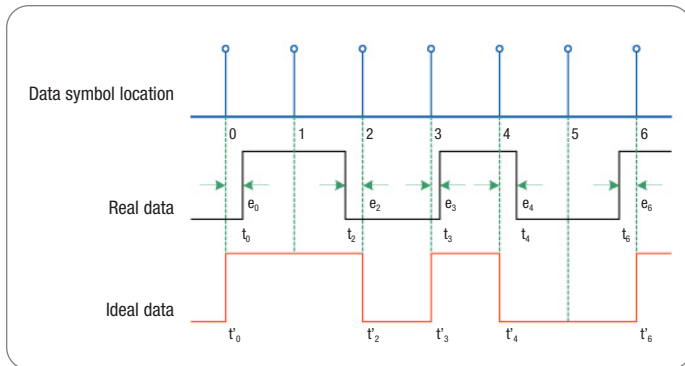

► **Figure 1.** Definition of jitter.

### Jitter and Its Components

Jitter is the deviation of the significant edges in a sequence of data bits from their ideal positions. As shown in Figure 1, jitter ( $e_i$ ) is the difference between the time ( $t'_i$ ) that an event is expected to occur and the time ( $t_i$ ) that the event actually occurs. In the context of a digital communications link, jitter is the offset between the expected position of the signal transition and the actual position of the transition.

In serial data communication, jitter can be a key problem since the data clock is usually not transmitted with the data. Because of this, excessive jitter on the transmitter data signal causes data recovery errors at the receiving end. To prevent excessive error rates, a jitter margin is specified in standards so that transmitting and receiving circuits can be designed to operate within jitter budget and tolerance. To ensure devices operate within these budgets, jitter needs to be measured precisely. The measurement should not only quantify jitter, but also help designers investigate the causes and sources of jitter to aid in reducing or eliminating the jitter source.

Jitter is divided into two generalized categories: deterministic jitter (Dj) and random jitter (Rj). These two categories of jitter accumulate differently in the serial data communication process. Rj is considered an unbounded component, normally fitting a Gaussian distribution and thus certain statistical rules. Dj is considered bounded, and is composed of ISI, DCD and Pj components.

**Dj** is Deterministic Jitter. It is predictable and consistent, and has specific causes. Dj is composed of ISI, DCD and Pj, and has a non-Gaussian amplitude distribution that is always bounded. Dj is characterized by its bounded, peak-to-peak value.

**ISI** is Inter-Symbol Interference. It is data-dependent deterministic jitter, typically caused by channel dispersion or filtering. It occurs when the signal arrives at the receiver threshold at different times when starting from different places in bit sequences (symbols). It is also referred to as Data Dependent Jitter (**DDj**).

**DCD** is Duty Cycle Distortion. It is the difference in the mean pulse width of the positive pulses compared to the mean pulse width of the negative pulses, in a clock-like bit sequence. It may be caused by amplitude-offset errors, turn-on delays and saturation.

**Pj** is Periodic Jitter. It repeats cyclically with a period that is not correlated to the data. A typical cause of Pj is power-supply feed through from a switching supply. Pj may be modeled by one or more sine waves and its/their harmonics.

**Rj** is Random Jitter. Rj exhibits a Gaussian distribution, which is theoretically unbounded in amplitude. The Gaussian distribution is characterized by its root-mean-square (RMS) value or standard deviation. One can easily show that, on average, any Gaussian random variable will exceed a span of 14 times its standard deviation only about one time in  $10^{12}$ . If exceeding this span causes a bit error in a data communications system, it corresponds to a bit error rate (BER) of  $10^{-12}$ . Rj is primarily due to thermal noise in electrical components.

**Tj** is Total Jitter. It is composed of Dj and Rj. For a BER of  $10^{-12}$ , its peak-to-peak value is calculated as follows:

$$TJ = DJ + RJ \times 14$$

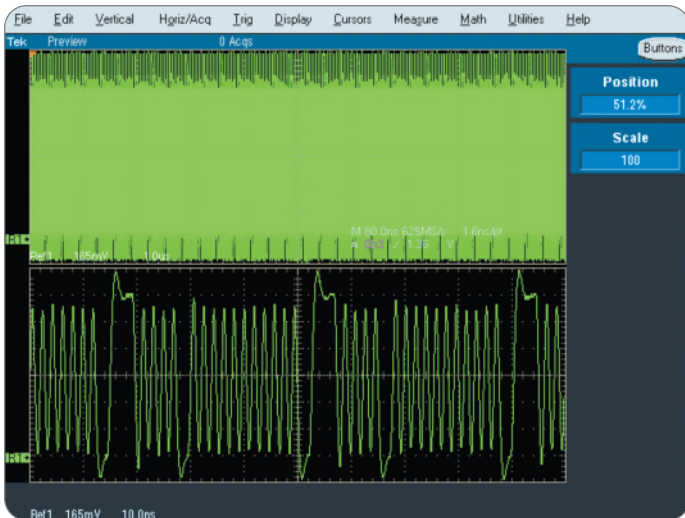

▶ **Figure 2.** Data signal with repeating pattern.

## Jitter Analysis Using a Spectrum Approach

In this approach, it is assumed that the serial data signal being measured consists of a periodically repeating pattern and the length of the repeating pattern is known. For example, the signal in Figure 2 contains repetitions of the Fibre Channel IDLE sequence of K28.5-D21.4-D21.5-D21.5. The pattern length is 40.

Using the spectrum approach, jitter is measured as follows:

An oscilloscope acquires a single shot or real time acquisition of the data signal. To most accurately capture the jitter, it is essential the acquisition system have the best available timing accuracy, signal to noise, effective bits, and signal fidelity. The Tektronix TDS6604 with TekConnect™ probes assures the best signal fidelity available today.

After the acquisition completes, the record is parsed by software to determine the time interval error for each of the clock edges. Depending on the users need, a least-squares or golden PLL method can be applied to recover the reference clock to find TIE. TIE represents the jitter in the acquired data edges.

### Golden PLL

When a data receiver processes a serial data stream, the receiver first recovers the timing reference, usually by means of a PLL. Jitter components that are within the loop bandwidth of the PLL are tracked by the PLL and thereby removed. Engineers frequently wish to measure only the jitter that would not be eliminated by such a PLL. The Fiber Channel Specification provides a reference PLL design, known as the “golden PLL,” to allow this form of clock recovery to be standardized. In TDSJIT3, the recovered clock is considered to be the reference clock and is used in the computation of Time Interval Error (TIE).

Then the TIE results are passed through an FFT to compute the spectrum of the TIE. This spectrum is the spectrum of the jitter in the acquired signal.

Before the spectrum is calculated, an important step is taken to ensure accuracy of the FFT result. For the points where there is no data edge between two or more symbols, especially NRZ data where levels may stay the same for multiple symbol periods, the group of symbols can be estimated by interpolation. The jitter value array is marked “interpolated” at these symbol locations so that it can be distinguished from jitter corresponding to transitions.

The spectrum approach yields the various components of the total jitter in two steps. In the first step,  $R_j$  and  $D_j$  are separated. In the second step,  $D_j$  components are separated.

## Jitter Analysis

► Application Note

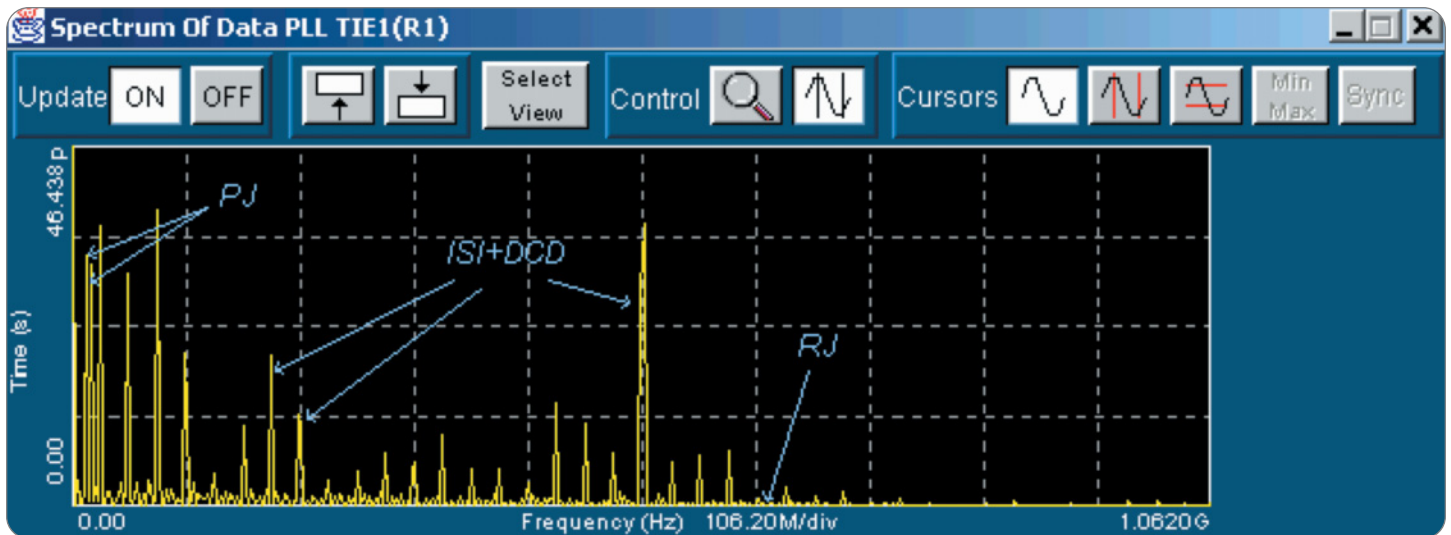

► **Figure 3.** Total jitter spectrum.

### Rj/Dj Analysis

The spectrum approach separates the total jitter into the two categories of Dj and Rj, based on the following observations:

- Rj is assumed to be Gaussian; its spectrum is broad and flat.
- Dj is periodic in the time domain since it is assumed that the serial data signal consists of a periodically repeating data pattern; it has a spectrum of impulses.

Figure 3 illustrates total jitter spectrum of the data signal shown in Figure 2. The different properties of Dj and Rj are obvious. Various approaches can be taken to separate the impulses from the 'noise floor,' but must accommodate variations in the FFT, resulting from FFT resolution, frequency spreading, windowing, etc. The standard deviation parameter of the Rj can be obtained by computing the RMS value of the noise floor in the frequency domain.

The Dj-only spectrum is recovered by setting to zero all bins from the Tj spectrum that are attributable to Rj. A time-domain record of the Dj is obtained by performing an inverse FFT on this Dj spectrum. The peak-to-peak time value, which is the parameter of interest for Dj, is found directly from this time-domain waveform. Note that locations marked earlier as "interpolated," are not counted when determining the peak-peak value.

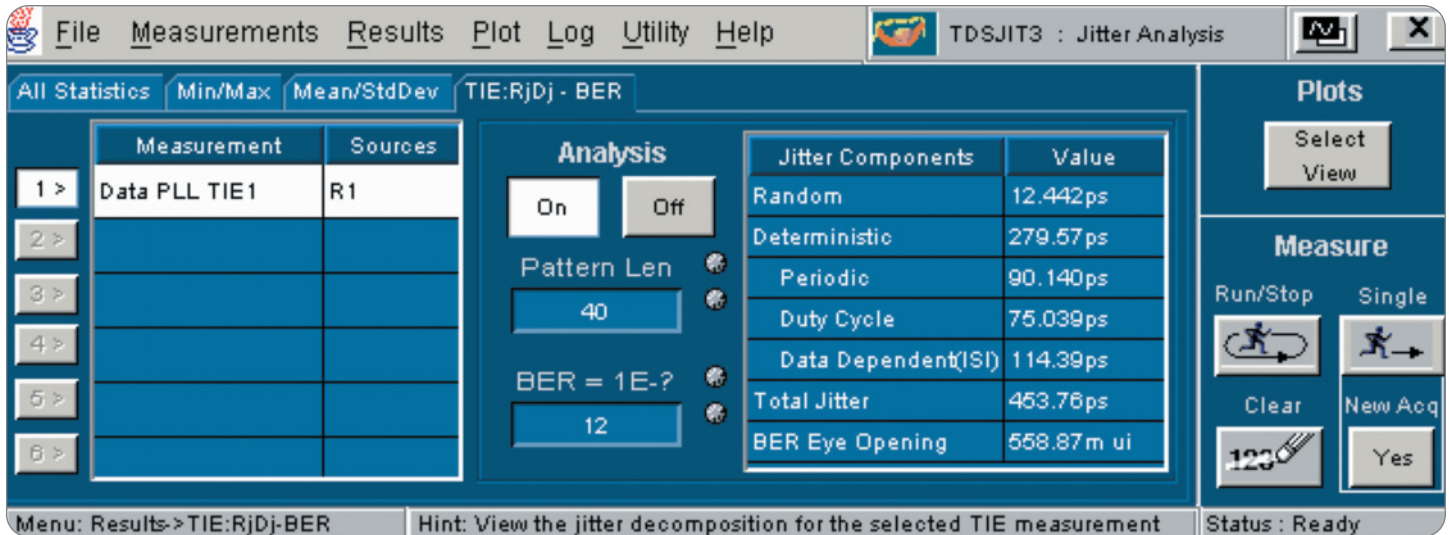

▶ **Figure 4.** Jitter component measurements.

### Analyzing Dj Components

After obtaining the spectrum of Dj in the previous step, the three components of Dj — ISI, DCD and Pj — can be obtained. Again, Dj consists solely of impulses. The ISI+DCD jitter components can be separated from the Pj component based on the following observations:

- ▶ All impulses due to ISI+DCD components must appear at multiples of  $0.5/N$ . Where N is the data pattern length, the number of symbols in the data sequence's repeat pattern.
- ▶ Any remaining impulses are due to Pj (refer to Figure 3).

With Pj thus isolated, an inverse FFT is performed to recover Pj in the time domain. The parameter of interest for the Pj is the peak-peak value of its time domain record. Then using only the portions of the Dj spectrum attributable to ISI+DCD, an inverse FFT is performed to recover ISI+DCD in the time domain. This time-domain record can now be separated into two records, where one record contains only the rising edges and the other contains only the falling edges. A histogram is computed for each. These two histograms can have similar shapes if the data signal has alternating disparity. The method used to distinguish DCD and ISI components from each other is based on the following properties:

- ▶ The difference between the mean values of the two histograms is DCD.
- ▶ The average of the peak-peak values of the histograms is ISI.

Using this spectrum approach, TDSJIT3 measures the jitter component values shown in Figure 4.

## Jitter Analysis

► Application Note

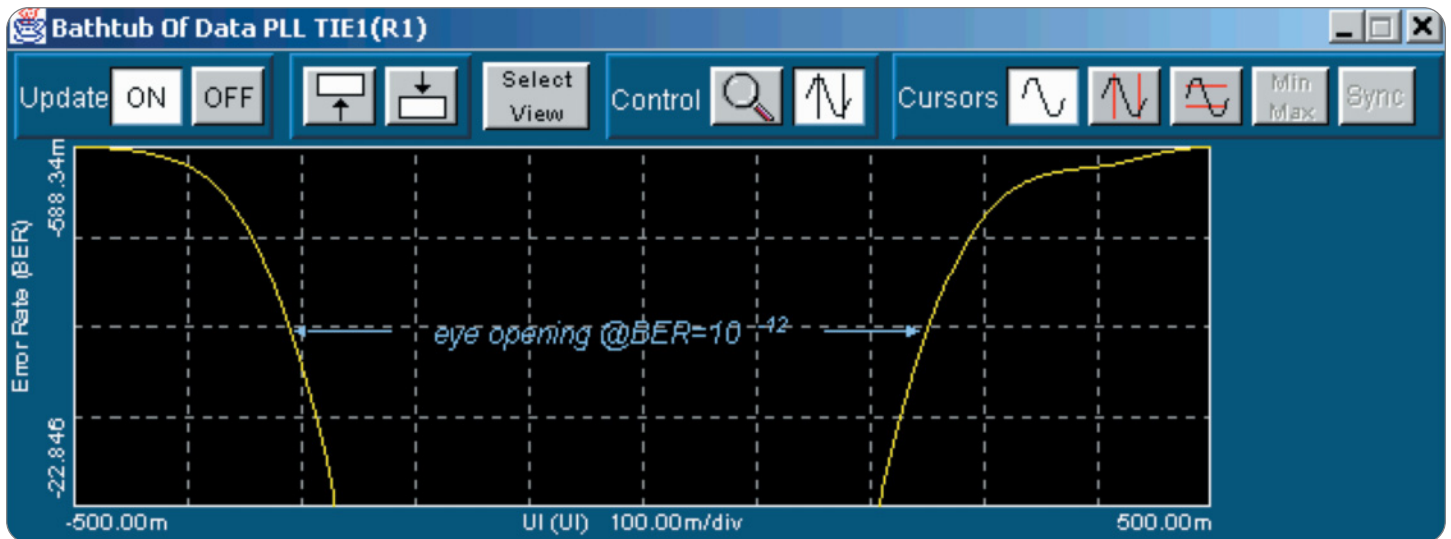

► **Figure 5.** Bathtub curve.

### Estimating Bit Error Rate

After deterministic jitter and random jitter have been separately characterized, the BER can be estimated. From the Dj/Rj separation, the time record of Dj is obtained. The time-domain histogram of the Dj is now computed, without counting those locations marked “interpolated.” The time-domain histogram of the Rj is synthesized based on its Gaussian model, using the standard deviation obtained during the Dj/Rj separation. The histograms of Dj and Rj are then convolved to get the recovered histogram of total jitter. This recovered Tj histogram, when properly normalized, can be interpreted as the probability distribution function (PDF) of the Tj.

Finally, the bathtub curve (BER curve, as shown in Figure 5) is obtained from this PDF. Additional details can be found in the Fibre Channel MJS document. Note that the bathtub curve is conventionally drawn using logarithmic scaling on the vertical axis, since the BER of interest corresponds to a level very near to zero. The decision error rate will always be lower than the bit error rate specified, as long as the decision time is chosen somewhere “in the bathtub.” This is analogous to ensuring the data sample point is centered in an oscilloscope eye diagram. Based on the BER bathtub curve, the eye opening can be estimated for a given bit error rate.

## Conclusion

As clock rates increase and timing budgets get smaller, timing characterization continues to become more important. With today's designs, you can't stop at characterizing jitter; you must also be able to investigate the causes of jitter by accurately measuring jitter and use it as a tool to predict system behavior over periods and with equipment that minimizes the total cost to your company. That means being able to analyze jitter using a spectrum approach on a multiuse tool like an oscilloscope. This results in designs being brought to market faster and made more robust to operate better in today's high-speed environment while minimizing the investment required for engineering tools.

### **The Value of Rj/Dj on a Real Time Oscilloscope**

Beyond the standard general and multiuse capabilities of Tektronix' open Windows based real-time oscilloscopes, analysis tools like TDSJIT3 allow engineers to perform complex and thorough analysis of signals extending the oscilloscope capability without bounds.

Tektronix has lead in signal fidelity and analysis since its inception. First with internal measurements; first with complex triggers; first with internal applications; first with open platforms; and now first with Rj/Dj.

The leading oscilloscope-based signal analysis company, Tektronix, continues to drive the industry forward, the benchmark others follow.

# Jitter Analysis

► Application Note

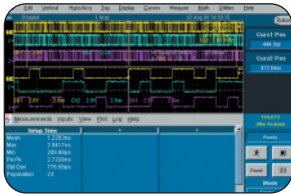

## TDSJIT3 Jitter Analysis Software

TDSJIT3 is the premiere jitter analysis software package. Being able to perform Rj/Dj analysis on clock and data signals, TDSJIT3 provides the highest accuracy jitter measurements available. With comprehensive jitter analysis algorithms, TDSJIT3 simplifies discovering jitter and its related sources in today's high-speed digital, communication and system designs.



## TDS6604 DSO

The world's first 6 GHz oscilloscope delivers the performance you need for your most demanding signals. The TDS6604 will take you to a higher level of signal integrity for next-gen digital designs by providing you with the performance you need to verify the integrity of your signals and a suite of tools that simplify and accelerate your design process. With 6 GHz bandwidth and 20 GS/s sample rate on 2 channels, the TDS6604 provides unmatched signal integrity measurements.

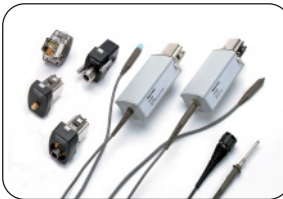

## High-Performance Probe Solutions

World-class Tektronix probes deliver world-class signal fidelity and performance. The P7260 is the fastest active FET probe in the world. Both the P7260 and the P7240 active probes, as well as the P7330 differential probe, provide low circuit loading, low noise and accurate probing solutions for high-speed circuit designers.

## Contact Tektronix:

**ASEAN Countries & Pakistan** (65) 6356 3900

**Australia & New Zealand** (65) 6356 3900

**Austria** +43 2236 8092 262

**Belgium** +32 (2) 715 89 70

**Brazil & South America** 55 (11) 3741-8360

**Canada** 1 (800) 661-5625

**Central Europe & Greece** +43 2236 8092 301

**Denmark** +45 44 850 700

**Finland** +358 (9) 4783 400

**France & North Africa** +33 (0) 1 69 86 80 34

**Germany** +49 (221) 94 77 400

**Hong Kong** (852) 2585-6688

**India** (91) 80-2275577

**Italy** +39 (02) 25086 1

**Japan** (Sony/Tektronix Corporation) 81 (3) 3448-3111

**Mexico, Central America & Caribbean** 52 (55) 56666-333

**The Netherlands** +31 (0) 23 569 5555

**Norway** +47 22 07 07 00

**People's Republic of China** 86 (10) 6235 1230

**Poland** +48 (0) 22 521 53 40

**Republic of Korea** 82 (2) 528-5299

**Russia, CIS & The Baltics** +358 (9) 4783 400

**South Africa** +27 11 254 8360

**Spain** +34 (91) 372 6055

**Sweden** +46 8 477 6503/4

**Taiwan** 886 (2) 2722-9622

**United Kingdom & Eire** +44 (0) 1344 392400

**USA** 1 (800) 426-2200

For other areas contact Tektronix, Inc. at: 1 (503) 627-7111

## For Further Information

Tektronix maintains a comprehensive, constantly expanding collection of application notes, technical briefs and other resources to help engineers working on the cutting edge of technology. Please visit [www.tektronix.com](http://www.tektronix.com)



Copyright © 2002, Tektronix, Inc. All rights reserved. Tektronix products are covered by U.S. and foreign patents, issued and pending. Information in this publication supersedes that in all previously published material. Specification and price change privileges reserved. TEKTRONIX and TEK are registered trademarks of Tektronix, Inc. All other trade names referenced are the service marks, trademarks or registered trademarks of their respective companies.  
03/02 HMH/PG 55W-15631-0